

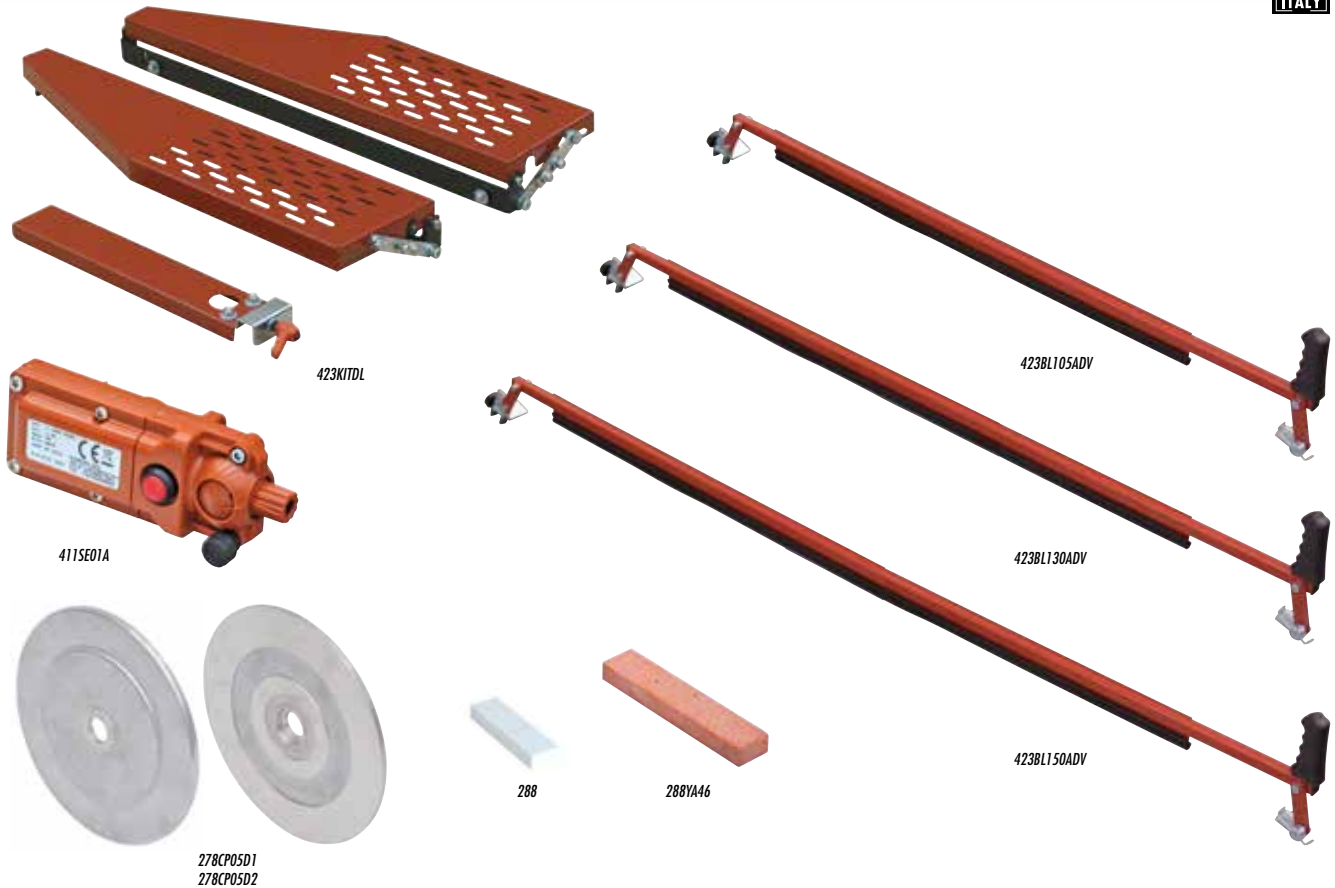

BRIDGE AND JOB SITE SAW MACHINES



Part No.			Description				
423KITDL	8024648010476	1	Optional kit: folding extension tables and 90° left square	71x22xh 10 cm	28" x8 5/8" xh 4"	5 Kg	11 lbs
423BL105ADV	8024648056757	1	Tile holder for Pikus 105 ADV, SMS 100, Zoe 105 ADV	117x24xh 20 cm	46" x9 1/2" xh 7 7/8"	2,6 Kg	5.7 lbs
423BL130ADV	8024648066459	1	Tile holder for Pikus 130 ADV, SMS 125, Zoe 130 ADV	153x24xh 20 cm	60" x9 1/2" xh 7 7/8"	3 Kg	6.6 lbs
423BL150ADV	8024648071187	1	Tile holder for SMS150 e Zoe 150 ADV	178x24xh 20 cm	70" x9 1/2" xh 7 7/8"	3,5 Kg	7.7 lbs
411SE01A	8024648065254	1	Laser without stirrup	-	-	-	-
411SE A1	8024648070906	1	Laser with stirrup for ZOE Adv	-	-	-	-
411SE A2	8024648070913	1	Laser with stirrup for Pikus Adv	-	-	-	-
411SE A4	8024648070937	1	Laser with stirrup for SMS100,125 e 150	-	-	-	-
411SE A9	8024648005663	1	Laser with stirrup for SMS220 e SMS260	-	-	-	-
288	8024648004178	1	Dressing stone 30 x100xh 15 mm (1 3/16" x 4" xh 5/8")	-	-	-	-
288YA46	8024648079619	1	Dressing stone 45x230xh 25 mm (1 3/4" x9 1/16" xh 1")	-	-	-	-
278CP05D1	8024648079060	2	Flanges (pair) Ø 200 mm (8") per Zoe ADV	-	-	-	-
278CP05D2	8024648079077	2	Flanges (pair) Ø 200 mm (8") per SMS e Mistral	-	-	-	-

Part No.	EXPLOIT			BOLT		MISTRAL		PIKUS		PIKUS ADV			SMS				LAB		ZOE ADV			SA	SA	SHERPA					
	70	90	120	90	120	150	90	120	150	75	85	105	130	100	125	150	220	260	270	330	85	105	130		150	80	09		
423KITDL	-	-	-	-	-	-	-	-	-	•	•	•	•	•	•	•	•	•	•	•	•	•	•	•	•	•	•	-	
423BL105ADV	-	-	-	-	-	-	-	-	-	-	-	•	-	•	-	-	-	-	-	-	-	-	-	-	-	-	-	-	
423BL130ADV	-	-	-	-	-	-	-	-	-	-	-	•	-	•	-	-	-	-	-	-	-	-	•	-	-	-	-	-	
423BL150ADV	-	-	-	-	-	-	-	-	-	-	-	-	-	-	-	-	•	-	-	-	-	-	•	-	-	-	-	-	
411SE01A	-	-	-	-	-	-	-	-	-	-	-	-	-	-	-	-	-	-	-	-	-	-	-	-	-	-	-	-	
411SE A1	-	-	-	-	-	-	-	-	-	-	-	-	-	-	-	-	-	-	-	-	-	•	•	•	•	-	-	-	
411SE A2	-	-	-	-	-	-	-	-	-	-	•	•	•	-	-	-	-	-	-	-	-	-	-	-	-	-	-	-	
411SE A4	-	-	-	-	-	-	-	-	-	-	-	-	-	•	•	•	-	-	-	-	-	-	-	-	-	-	-	-	
411SE A9	-	-	-	-	-	-	-	-	-	-	-	-	-	-	-	-	•	•	•	-	-	-	-	-	-	-	-	-	
288	•	•	•	•	•	•	•	•	•	•	•	•	•	•	•	•	•	•	•	•	•	•	•	•	•	•	•	•	•
288YA46	•	•	•	•	•	•	•	•	•	•	•	•	•	•	•	•	•	•	•	•	•	•	•	•	•	•	•	•	•
278CP05D1	-	-	-	-	-	-	-	-	-	-	-	-	-	-	-	-	-	-	-	-	-	-	•	•	•	•	-	-	
278CP05D2	-	-	-	-	-	-	-	-	-	-	-	-	-	-	-	-	-	-	-	-	-	-	-	-	-	-	-	-	





ACCESSORIES FOR BRIDGE SAW MACHINES

MADE IN ITALY



Part No.			Description				
374RU5D40I	8024648090256	1	Self-standing 5 rollers side extension bench (length: 705mm; width: 506 mm)	80x60xh 20	31 1/2"x23 5/8"x h7 7/8"	20,7 Kg	45.6 lbs
191CL04A1	8024648080998	1	Telescopic set-square 90°/45° for Pikus Adv, SMS and Zoe Adv	80x33xh 21 cm	31 1/2"x13"xh 8 1/4"	9 Kg	19.8 lbs
192SQ03A	8024648014986	1	Sliding square 90°	42x7xh 5 cm	16 1/2"x2 3/4"xh 2"	900 gr	31.8 oz
192SQ07A	8024648053893	1	Left sliding square 45°/90°	29x22xh 7 cm	11 1/2"x8 5/8"xh 2 3/4"	900 gr	31.8 oz
191CL04A	8024648056122	1	Side square for Pikus ADV, Zoe ADV and SMS	81x45xh 13 cm	32"x17 3/4"xh 5"	4,5 Kg	10 lbs
191CL04A2	8024648088123	1	Side square for Exploit 90,120,150 and Mistral 90,120,150	100x45xh 12cm	39 3/8"x17 3/4"xh 4 3/4"	5,6 Kg	12.3 lbs
191CL05A	8024648058003	1	Side square for rolling side tables	68x66xh 10cm	27"x26"xh 4"	4,5 Kg	9.9 lbs
315CR02K	8024648089908	1	4 Wheels + handles kit for Exploit, Bolt and Mistral	33x33xh 10 cm	13"x13"xh 4"	3,3 Kg	7.3 lbs
263PE04A085	8024648019585	1	Water containment bars with nylon brushes for Pikus 85 Adv and Zoe 85 Adv	120xØ 12,5 cm	47 1/4"xØ 5"	3,6 Kg	7.9 lbs
263PE04A105	8024648019592	1	Water containment bars with nylon brushes for Pikus 105 Adv, SMS 100 and Zoe 105 Adv	120xØ 12,5 cm	47 1/4"xØ 5"	3,8 Kg	8.4 lbs
263PE04A130	8024648022233	1	Water containment bars with nylon brushes for Pikus 130 Adv, SMS 125 and Zoe 130 Adv	165xØ 12,5 cm	65"xØ 5"	4,6 Kg	10.1 lbs
263PE04A150	8024648022851	1	Water containment bars with nylon brushes for SMS 150 and Zoe 150 Adv	165xØ 12,5 cm	65"xØ 5"	4,9 Kg	10.8 lbs
263PE04A200	8024648026507	1	Water containment bars with nylon brushes for SMS 220	200xØ 12,5 cm	79"xØ 5"	6,6 Kg	14.6 lbs
263PE04A260	8050532001824	1	Water containment bars with nylon brushes for SMS 260	285xØ 12,5 cm	112"xØ 5"	7,6 Kg	16.8 lbs

Part No.	EXPLOIT			BOLT			MISTRAL			PIKUS				PIKUS ADV				SMS				LAB		ZOE ADV				SA 80	SA 09	SHERPA
	70	90	120	90	120	150	90	120	150	75	85	105	130	100	125	150	220	260	270	330	85	105	130	150						
374RU5D40I	•	•	•	•	•	•	•	•	•	•	•	•	•	•	•	•	•	•	•	•	•	•	•	•	•	•	•	•		
191CL04A1	-	-	-	-	-	-	-	-	-	-	-	-	-	-	-	-	-	-	-	-	-	-	-	-	-	-	-	-		
192SQ03A	•	•	•	•	•	•	•	•	•	•	•	•	•	•	•	•	•	•	•	•	•	•	•	•	•	•	•	•		
192SQ07A	•	•	•	•	•	•	•	•	•	•	•	•	•	•	•	•	•	•	•	•	•	•	•	•	•	•	•	•		
191CL04A	-	-	-	-	-	-	-	-	-	-	-	-	-	-	-	-	-	-	-	-	-	-	-	-	-	-	-	-		
191CL04A2	-	•	•	•	•	•	•	•	•	•	•	•	•	-	-	-	-	-	-	-	-	-	-	-	-	-	-	-		
191CL05A	-	-	-	-	-	-	-	-	-	-	-	-	-	-	-	-	-	-	-	-	-	-	-	-	-	-	-	-		
315CR02K	•	•	•	•	•	•	•	•	•	•	•	•	•	-	-	-	-	-	-	-	-	-	-	-	-	-	-	-		
263PE04A085	-	-	-	-	-	-	-	-	-	-	-	-	-	-	-	-	-	-	-	-	-	-	-	-	-	-	-	-		
263PE04A105	-	-	-	-	-	-	-	-	-	-	-	-	-	-	-	-	-	-	-	-	-	-	-	-	-	-	-	-		
263PE04A130	-	-	-	-	-	-	-	-	-	-	-	-	•	-	-	-	-	-	-	-	-	-	-	-	-	-	-	-		
263PE04A150	-	-	-	-	-	-	-	-	-	-	-	-	-	-	-	-	-	-	-	-	-	-	-	-	-	-	-	-		
263PE04A200	-	-	-	-	-	-	-	-	-	-	-	-	-	-	-	-	-	-	-	-	-	-	-	-	-	-	-	-		
263PE04A260	-	-	-	-	-	-	-	-	-	-	-	-	-	-	-	-	-	-	-	-	-	-	-	-	-	-	-	-		



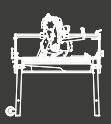

MANUAL FEED KIT WITH WHEEL



Part No.			Description
419AVBO=120	8024648090331	1	Wheel kit feed for Bolt 120
419AVBO=150	8024648090348	1	Wheel kit feed for Bolt 150
419AVMS=120	8024648090355	1	Wheel kit feed for Mistral 120/SMS 125
419AVMS=150	8024648090362	1	Wheel kit feed for Mistral 150
419AVMS=155	8024648022714	1	Wheel kit feed for SMS 150
419AVPK 085	8024648091543	1	Wheel kit feed for Pikus 85 Adv
419AVPK 105	8024648091550	1	Wheel kit feed for Pikus 105 Adv
419AVPK 130	8024648092755	1	Wheel kit feed for Pikus 130 Adv
419AVZVO 085	8024648093233	1	Wheel kit feed for Zoe 85 Adv
419AVZVO 105	8024648093240	1	Wheel kit feed for Zoe 105 Adv
419AVZVO 130	8024648093257	1	Wheel kit feed for Zoe 130 Adv
419AVZVO 150	8024648093264	1	Wheel kit feed for Zoe 150 Adv

Part No.	EXPLOIT			BOLT			MISTRAL			PIKUS			PIKUS ADV			SMS			LAB		ZOE ADV				SA	SA	SHERPA
	70	90	120	90	120	150	90	120	150	75	85	105	130	100	125	150	220	260	270	330	85	105	130	150	80	09	
419AVBO=120	-	-	-	•	-	-	-	-	-	-	-	-	-	-	-	-	-	-	-	-	-	-	-	-	-	-	-
419AVBO=150	-	-	-	-	•	-	-	-	-	-	-	-	-	-	-	-	-	-	-	-	-	-	-	-	-	-	-
419AVMS=120	-	-	-	-	-	-	•	-	-	-	-	-	-	-	•	-	-	-	-	-	-	-	-	-	-	-	-
419AVMS=150	-	-	-	-	-	-	-	-	•	-	-	-	-	-	-	-	-	-	-	-	-	-	-	-	-	-	-
419AVMS=155	-	-	-	-	-	-	-	-	-	-	-	-	-	-	-	•	-	-	-	-	-	-	-	-	-	-	-
419AVPK 085	-	-	-	-	-	-	-	-	-	-	•	-	-	-	-	-	-	-	-	-	-	-	-	-	-	-	-
419AVPK 105	-	-	-	-	-	-	-	-	-	-	-	•	-	-	-	-	-	-	-	-	-	-	-	-	-	-	-
419AVPK 130	-	-	-	-	-	-	-	-	-	-	-	-	•	-	-	-	-	-	-	-	-	-	-	-	-	-	-
419AVZVO 085	-	-	-	-	-	-	-	-	-	-	-	-	-	-	-	-	-	-	-	-	-	•	-	-	-	-	-
419AVZVO 105	-	-	-	-	-	-	-	-	-	-	-	-	-	-	-	-	-	-	-	-	-	-	•	-	-	-	-
419AVZVO 130	-	-	-	-	-	-	-	-	-	-	-	-	-	-	-	-	-	-	-	-	-	-	-	•	-	-	-
419AVZVO 150	-	-	-	-	-	-	-	-	-	-	-	-	-	-	-	-	-	-	-	-	-	-	-	-	•	-	-



ACCESSORIES FOR TROLLEY MACHINES



Part No.			Description		
192SQ24A	8024648005656	1	Adjustable square 0/45°/90° for SA80, SA09, SHERPA	40x17xh 8 cm	1,5 Kg 3.3 lbs
218DJ	8024648009777	1	Jolly device for SA09	71x23xh 11cm	28°x9°xh 4" 4,4 Kg 9.7 lbs
191CLO5A	8024648058003	1	Side square for SA80	68x66xh 10cm	27°x26°xh 4" 4,5 Kg 9.9 lbs
411SE01A	8024648065254	1	Laser without stirrup	-	-
411SE A4	8024648070937	1	Laser with stirrup for SMS and SA80	-	-
411SE A3	8024648070920	1	Laser with stirrup for Sherpa	-	-
288	8024648004178	1	Dressing stone 30 x100xh 15 mm (1 3/16" x 4" xh 5/8")	-	-
288YA46	8024648079619	1	Dressing stone 45x230xh 25 mm (1 3/4" x 9 1/16" xh 1")	-	-

Part No.	EXPLOIT			BOLT			MISTRAL			PIKUS			PIKUS ADV			SMS			LAB		ZOE ADV				SA	SA	SHERPA
	70	90	120	90	120	150	90	120	150	75	85	105	130	100	125	150	220	260	270	330	85	105	130	150	80	09	
192SQ24A	-	-	-	-	-	-	-	-	-	-	-	-	-	-	-	-	-	-	-	-	-	-	-	-	•	•	•
218DJ	-	-	-	-	-	-	-	-	-	-	-	-	-	-	-	-	-	-	-	-	-	-	-	-	-	•	-
191CLO5A	-	-	-	-	-	-	-	-	-	•	•	•	•	•	•	•	•	•	•	•	•	•	•	•	•	•	-
411SE01A	-	-	-	-	-	-	-	-	-	-	-	-	-	-	-	-	-	-	-	-	-	-	-	-	-	-	-
411SE A4	-	-	-	-	-	-	-	-	-	-	-	-	-	-	•	•	•	•	•	•	•	•	•	•	•	•	-
411SE A3	-	-	-	-	-	-	-	-	-	-	-	-	-	-	-	-	-	-	-	-	-	-	-	-	-	-	-
288	•	•	•	•	•	•	•	•	•	•	•	•	•	•	•	•	•	•	•	•	•	•	•	•	•	•	•
288YA46	•	•	•	•	•	•	•	•	•	•	•	•	•	•	•	•	•	•	•	•	•	•	•	•	•	•	•